



RADE RACKMOUNT SHIPPING CASES

Engineering for the Next Generation



Rapid Access Double Entry

RADE: Rapid Access Double Entry Cases

We took all the best features of our Industry Leading Rugged Rotomolded Rackmount Cases, and added Front Opening Catches that allow for Rapid Access to your equipment!

Hardigg's extra-rugged rotomolded Rackmount Cases have proven themselves thousands of times by saving sensitive equipment from transportation damage. Our proven 19" EIA Versa-Rack is the strongest, most secure aluminum rack in the industry, and our precision tuned elastomeric shockmount systems provide maximum protection from shock and vibration. Hardigg's reputation for innovation and engineering excellence is unequalled, and relied upon by customers worldwide. The industry didn't offer an easy-to-use,

"Hardigg's extra-rugged rotomolded Rackmount Cases have proven themselves thousands of times by saving sensitive equipment from transportation damage."

reliable sealing, closure device that would allow lids to be opened and closed while in a stacked position, so we did what we do best ... we designed one. Our unique, patented Rapid Access Catch has been designed for the real world. It's extra-durable, to handle years of frequent operation, and rugged use. Easy to use, and masterfully designed, the RADE Case is engineered for The Next Generation!

Hardigg's Patented Rack Frame System

Hardigg Rackmount cases provide the finest off-the-shelf assurance available for delicate payloads. Superior engineering experience applied to the critical areas of case design ensures the survival of your equipment and the reusability of the case. Hardigg Cases is proud to offer our patented rack frame system to meet your transport case requirements. Some of the innovative features built into each rack include:

- Rack components are aircraft quality precision extrusions made of tempered 6061-T6 aluminum, providing a high strength-to-weight ratio.
 - The Hardigg RADE case equipped with a 16 mount suspension system meets drop test requirements per MIL-STD-810E Method 516.3 including 8 corner drops from 24" high, with dummy weight of 200 lbs. mounted in the rack, for a gross weight of 273 lbs.



- Industry Standard EIA-310-C for Universal Rack Mounting hole pattern, on both the outside and inside of the rack uprights for maximum versatility of accessories interface.
- Each rack corner is held by interference fit spiral spring pins for high shear strength and low insertion force to maximize structural integrity.
- The eight corners of the rack are internally reinforced with a solid aluminum extruded connector to maintain functional squareness of the frame structure even after the dynamic twisting forces of loaded container drop impacts.
- Superior alignment is maintained with minimal material stress. Components of the rack are socketed and mechanically pinned together, resulting in maximum joint strength without the risk of any welding-induced warping or cracking.

Accessories



Pressure Relief Valve

Includes all gasketing required to safely maintain controlled pressure differential.

Shelves, Fixed and Sliding

Shelves can easily be removed & customized to accommodate non-rack mountable equipment.



Storage Pouch

Zippered pouch for storing cables and accessories in front and/or rear lids. Comes mounted in lid. One size, 22" X 12".

Lifting Ring/Tie Down Ring

Bolt-mounted with backup plates for hoisting or tie-down of case. Ring is spring-loaded and pivots 180 degrees. Available: Stainless Steel Black

Comfort Grip Handle

Injection molded from high density polyethylene this heavy duty Comfort Grip handle is rustproof and large enough to accommodate a gloved hand. This handle is rated to 150 lb lift/handle.

Locking Cable/Hasp

Allows the case to be pad-locked shut. The cable is made of tamper-resistant aircraft steel. (Order two (2) each for each lid.) (4 per case)



Heavy-Duty Fixed and Removable Casters

Removable or fixed, recessed caster holder design. Double ball bearing action. 3.5" or 5"

Enclosed Storage Drawers with Slides and Keylock

Drawers are 14" deep (front to back) and available in 2U, 3U and 4U heights (1U = 1.75")



Lid Bench

Used for converting rack case lids to a table or seat (bench). Legs are stored in lid during transport, then clipped onto lid using the one-button FastClip™ system. Table leg set included with writing surface mounted in lid. Available with 12" or 20" long legs.



Card Holder

Metal holder for shipping-card, riveted to the exterior of case. Two sizes (3" X 5" or 4" X 6").



Specs

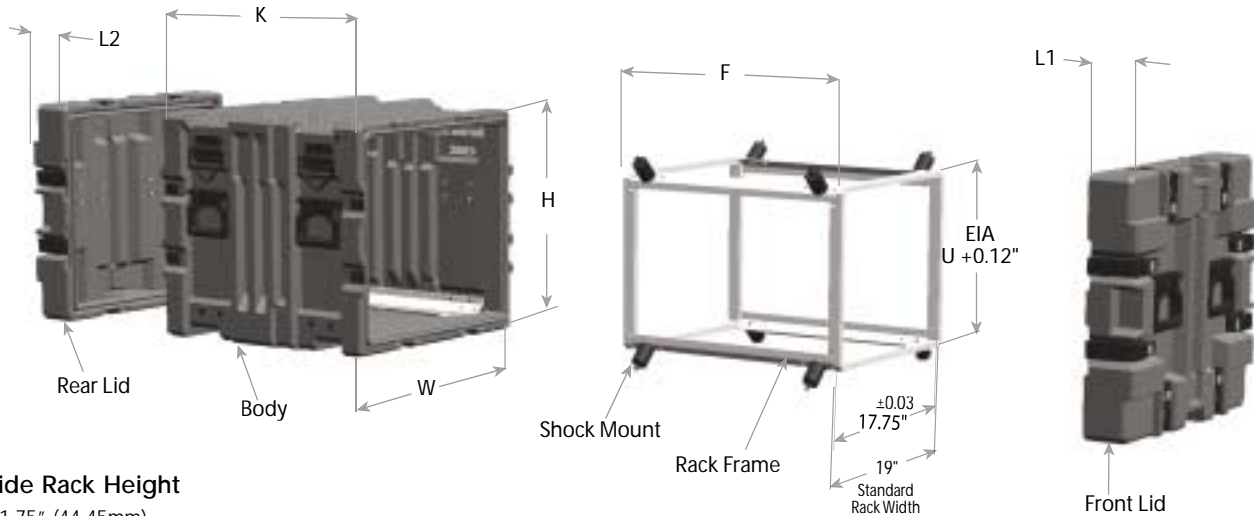

Inside Rack Height

U = 1.75" (44.45mm)

i.e. 9U = 15.75" (400mm) plus

0.12" (3mm) = 15.87" (403mm) inside height

Example: Case Size Number

RD 22 29- 03 / 26 / 03

Please note all dimensions are nominal.

L2 = Lid Interior Depth 3.43" / 87mm Exterior depth 4.87" / 123mm

K = Case Body Interior Depth 26" / 660mm (for exterior dim. add 0")

L1 = Lid Interior Depth 3.43" / 87mm Exterior depth 4.87" / 123mm

H = Case Body Interior Height (29" / 736mm) (for exterior dim. add 3" / 76mm)

W = Case Body Interior Width 22.12" / 561mm (for exterior dim. add 3" / 76mm)

Rapid Access Double Entry

Standard Rackframe Load Ranges	
Shockmounts Per System	Load Ranges (lbs/kg) For Equipment Installed in Rack
8 ea	20 to 40 lbs / 9.1 to 18.1 kg
8 ea	40 to 60 lbs / 18.1 to 27.2 kg
8 ea	60 to 80 lbs / 27.2 to 36.3 kg
8 ea	80 to 100 lbs / 36.3 to 45.4 kg
8 ea	100 to 170 lbs / 45.4 to 77.1 kg
16 ea	160 to 200 lbs / 72.6 to 90.7 kg
16 ea	*200 to 340 lbs / 90.7 to 154.2 kg

Case Body Length	K	26" 660mm
Rack Length	F	24" 609mm

*For weights over 350 lbs call for assistance

Case Size Part Number	U-Size Inches Millimeters	Shipping Cube FT ³	approx. Shipping Net Wt LBS/KG
RD2213-03/26/03	5U / 8.87" / 225mm	9.12	59 / 26.8
RD2221-03/26/03	9U / 15.87" / 403mm	12.76	69 / 31.3
RD2224-03/26/03	11U / 19.36" / 492mm	14.45	74 / 33.6
RD2229-03/26/03	14U / 24.62" / 625mm	16.67	85 / 38.5